



EUROSHIELD®

THE SMART CHOICE IN ROOFING

Recommended installation procedures for Vermont Slate Panel Loc and Vermont Slate Panel Loc HP (Hail Proof)

Do not begin installation until you have read and fully understand the procedures outlined in this Guide. Take special note of the Layout Patterns at the back of this guide and follow the layout for your mold number (marked on the product).

Note: proper sealant placement on the panels and in the locking channel is important to a successful installation. Take note of the procedures found on pages 12, 16, and 25.

Note: Snow can accumulate and slide off Euroshield roofing. Installers and homeowners should assess the need for snow retention systems and apply during the installation process.

NOTE: VERMONT SLATE LOC SKIDS ARE NOT STACKABLE. PLEASE DO NOT DOUBLE- STACK SKIDS OR PLACE ITEMS ON TOP OF PRODUCT.

Contact us at:

9330 – 48th Street SE
Calgary, Alberta, Canada
T2C 2R2

Office (403) 215-3333
Toll Free (877) 387-7667
Fax (403) 287-2012

Website: www.euroshieldroofing.com
Email: info@euroshieldroofing.com

G.E.M. Inc. is the manufacturer & distributor of EuroShield® rubber roof roofing systems manufactured in Calgary, Alberta, Canada.

CCMC (Canadian Construction Materials Council) Reg. Number 12118-R

Ver. 020120S

TABLE OF CONTENTS

- Introduction
 - corporate profile
 - Feature / benefit page
- Components
 - spec data sheets
 - Packaging, handling
- Pre-installation
 - system introduction
 - Roof deck, structure, load, eave protection
 - ice dam, re-roofing, slope
 - underlay
 - ventilation
 - fastening, impact, shading, fade
- Installation
 - deck, eave protection, loading, valleys, protrusions, openings
 - Starter tile, field tile
 - Ridge, gable, hip caps
 - detail finishing, maintenance, flashing profiles



INTRODUCTION

Corporate profile

Calgary based Global Environmental Manufacturing Inc. (GEM), founded by Henry Kamphuis in 1999, has developed innovative technology to produce competitively priced, premium quality building products using approximately 95% recycled materials (e.g. recycled tires). GEM's unique technology, insulation properties and product design is capable of producing significant energy benefits and savings. The product is competitively priced while being ultra-environmentally friendly. GEM's proprietary, unique Reinforced Rubber Based Compound including carbon black forms the basis of all of GEM's products. Aside from adding durability and strength, Carbon Black is widely considered the best U.V. inhibitor in the world.

GEM's EuroShield® Roof is a pitched roofing system using rubber-based panels. Its unique selling features include unsurpassed durability and protection against all the elements and a simple installation resulting in a significant reduction in labour costs in comparison to other premium products. GEM's roofing system also provides an enhanced aesthetic appeal while providing superior lasting protection.

Features and benefits

- Long lasting, durable
- Aesthetically pleasing
- Flexible and versatile
- Weather resistant
- Environmentally friendly
- Fast and easy to install
- Hail resistant with a 2" Hail damage warranty (Vermont Slate Panel Loc HP is Hail Proof*)
- Very Lightweight (VermontSlate -2.40lbs per sq/ft and Vermont Slate HP 2.6lbs per sq.ft)
- Affordable
- Potential discount on homeowners insurance policy
- Maintenance free
- Keeps your house cooler in the summer and warmer in the winter
- Fire resistant
- Increases the value of your home

EuroShield® is the most advanced roofing system in the market today.

*Hail Proof warranty coverage for the first 20 years after install followed by 30 years of 2" hail coverage. See warranty for details.

Components

Spec data sheet

Vermont Slate Panel Loc/Vermont Slate Panel Loc HP

(referenced as “Vermont Slate” and “Vermont Slate HP” in guide)

Weight/pc 6lbs/6.5lbs approx.

Pieces/sq 40

Bundles/sq. 4

Pieces/Bundle 10

Lbs/sq. 240/260

Length 40”

Width 20”

Exposure/panel 2.5sq.ft

Exposure/To-the-Weather 9” x 40” (5-8” wide sections per panel)

Butt edge thickness is approximately ½”

Ridge cap (same as hip cap)

Weight .88 lb. approx.

Length 18” approx.

Width 2 angles each side approx. 5.0”

Exposure 9” approx.

Hip cap

Weight/pc .88 lb approx.

Length 18” approx.

Width 2 angles each 5.0” approx.

Exposure 9” approx.

Starter Strip 3.5 lbs (40”W x 11.1”H)

Packaging and handling

Vermont Slate Panel Loc

10 panels per bundle (coverage/bundle = 25.00 sq.ft)

4 bundles per square (100 sq.ft TTW)

320 pcs/pallet – 32 bundles

Vermont Slate Panel Loc/Vermont Slate Panel Loc HP – 1,970 lbs/2,115lbs incl. skid

Ridge Cap

12 caps per bundle (coverage/bundle – 9 lin.ft)

Hip Cap

12 caps per bundle (coverage/bundle – 9 lin.ft)

Starter Strip Eave Locking

10 pieces per bundle

Coverage/bundle = 33.3 lin.ft

Starter Strip Rake and Valley

12 pieces per bundle

Coverage/bundle = 40 lin.ft

Note: All products ordered by the bundle.

PRE-INSTALLATION

System Introduction

This manual contains the acceptable requirements for GEM's Locking Vermont Slate Roofing System. Installation specifications and details are designed for slopes 4/12 or steeper. Low slope applications less than 4/12 may warrant extra precautions; please contact GEM to qualify your particular circumstances and conditions.

If installing on a Mansard or vertical slope, please contact us prior to installing.

No exposed standard roofing nails are permitted when installing Euroshield® products.

This installation manual establishes a standard for the EuroShield® System that meets or exceeds the requirements of CMHC and the National Building Code of Canada (2005).

Installers must familiarize themselves with the contents of this installation manual in order that the EuroShield® System is installed to its uncompromised standard.

GEM reserves the right to limit or cancel the sale of EuroShield® products should installation of the products not meet or exceed our standards.

These recommended installation procedures may be amended as required from time to time.

As long as the minimum standards of installation are adhered to in accordance with this installation manual, installation practices and procedures may be modified; however, installers must comply with local building code standards in keeping with the needs and requirements for their area and application.

ROOF DECK

The roof area shall be sheathed with plywood, OSB or equivalent; and deck thickness must satisfy the requirements of the Building Code in effect for the region you are installing in. Distance between support trusses or joists should not exceed 600mm (24"). Contact our technical department for individual attention should qualify distances exceeding 600mm (24"). Sheathing shall be fastened and clipped unless otherwise approved by G.E.M. Inc.

STRUCTURE AND LOAD REQUIREMENTS

There are no special structural changes or enhancements to make or special load requirements necessary for GEM's EuroShield® Roof. The roof structure and load requirements must meet the requirements of the National Building Code (or corresponding province/state building code where applicable).

EAVE PROTECTION

Eave protection materials must conform to National Building Code. Install protection membrane material along all eaves overhanging fascia 25mm (1"). End laps of material are to be 150mm (6") and sealed according to manufacturer's instructions. Use an ice/water membrane that meets or exceeds requirements set out in the building code for the region.

Roof systems will sometimes fail due to the formation of ice dams. Ice dams are formed by the continuous melting and freezing of snow and the backing up of frozen slush from the gutters, due to heat escaping from the house. The melted water flows under the snow and freezes as it reaches the unheated soffit, thus creating the ice dam. When this occurs, water can be forced under the panels and into the attic, causing damages to the home's ceilings, walls, insulation, gutters, eaves and roof.

To reduce ice dam formation and help minimize ice dam problems:

1. Keep the attic space cold by insulating it from the warm house interior, thus reducing or eliminating snow melt.
2. Use high heel trusses, insulate to the outside of the plates and install cardboard baffles to ensure ventilation at the eaves.
3. Ensure that the outer edges of the gutters or eavestroughs are lower than the slope line to allow snow and ice to slide clear. Also ensure gutters are free of debris.

Reference: Canadian Mortgage and Housing Corporation, Roofing and Flashing Problems, publication NHA 6076.

In areas where snowfall occurs, snow guards may be required to help prevent slides from the roof surface to the ground below. If snow guards are to be used with the Euroshield® product, they should be applied at the time of installation. It is the responsibility of the installation contractor, in conjunction with the homeowner, to determine the suitability of installing snow guards on the roof, unless specified in the local building code. GEM Inc. assumes no responsibility for the supply or install of these devices on the roof.

In high snow areas with a ground snow load greater than 3.5 kPa as identified in Chapter 1 of the supplement to the National Building Code of Canada, the eaves protection must extend from the edge of the roof to a minimum distance of 1700mm (67") up the roof to a line not less than 1100mm (43 ½") inside the inner beam.

Fasten and adhere the protection material to the sheathing sufficiently to prevent wind up lift and damage with hot galvanized or coated fasteners.

Valleys utilize the same materials as eaves protection. Material is applied parallel to valley centerline with half roll width on each side of the centreline and overhanging the fascia and eaves 25mm (1"). In areas with high snowfall combined with freeze thaw conditions use double roll width extending 860mm (34") to both sides including 100mm (4") lap at centreline.

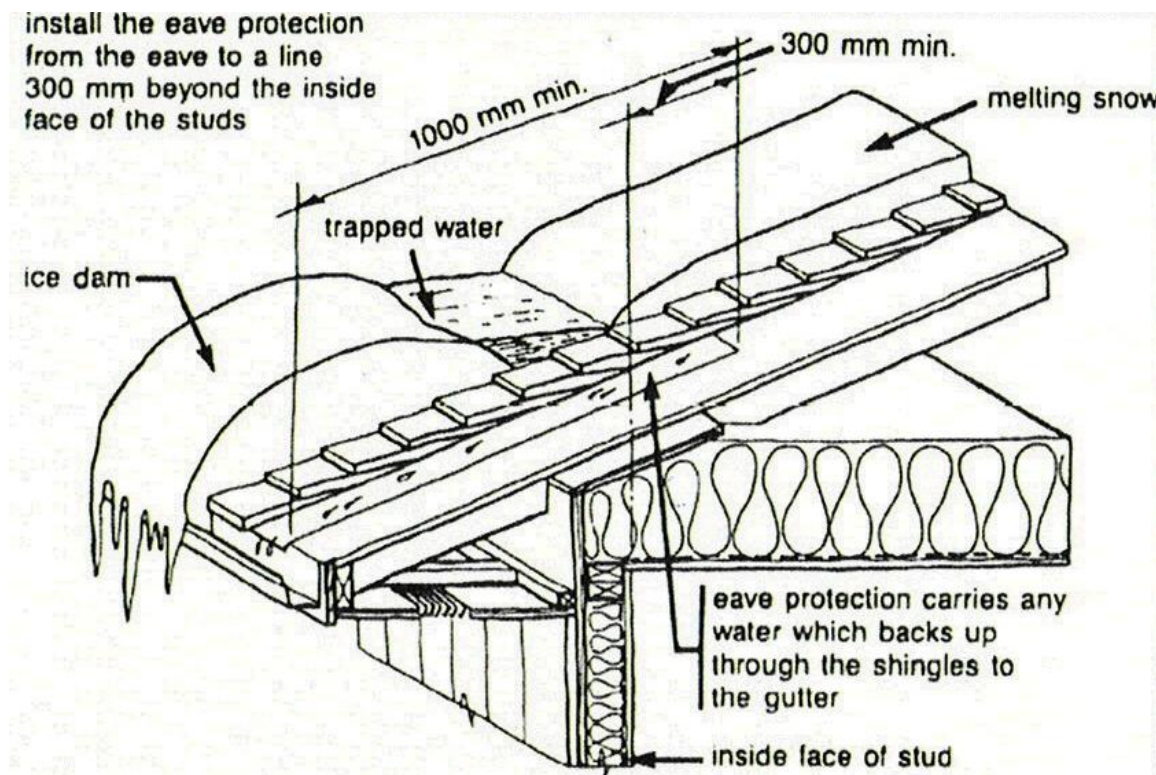

RE-ROOFING

As Euroshield® is a permanent roofing product; it is imperative that the existing roof and the underlying roof structure are inspected to determine whether the substrate has not rotted and is of enduring quality. EuroShield® should not be installed over an existing roof covering; asphalt shingles, shakes or other. Remove existing roof covering to ensure trusses, sheathing fascia and other components including masonry, plumbing and mechanical are in good repair to support the EuroShield® System throughout its durable lifetime. In any case, the existing roof covering (asphalt, cedar, pine or other) must be removed and repairs or replacement of deteriorated components undertaken prior to installation of a Euroshield® roof. Please contact G.E.M. Inc. regarding any planned deviation from the above noted guidelines.

SLOPE

EuroShield® was designed to be installed on roofs with a slope of 4/12 or greater as described in the National Building Code. For low slope application (less than 4/12), contact our technical department at (877) 387-7667 prior to the installation of Euroshield® products. The installation of Euroshield® roofing products is not recommended on sloped roofing with a pitch of 2/12 or less.

UNDERLAY

In standard applications, whether installing on new sheathing or on existing sheathing, install ice dam protection and woven synthetic (plastic/polymer/fiber reinforced) underlay, as described in the National Building Code (or corresponding province/state code where applicable). Note that though your building codes may not require underlay on the entire roof, GEM's warranty does require it.

There are many reasons why the use of underlayment prior to applying Euroshield® makes good roofing sense.

- Underlayment protects the wooden deck from the moisture penetration until the EuroShield® is applied, thus greatly reducing problems to structure.
- Installing underlayment helps to minimize “picture framing”, i.e. the visible outline of deck panels cause by irregularities in roof construction.
- The water resistance of underlayment provides secondary protection by helping to shield the deck from wind-driven rain.
- Underlayment offers protection to the EuroShield® from the resins that can be released by the wood decking.
- The underlayment material should meet the following industry standard:

Synthetic Woven Underlayment - In accordance with approved alternative to ASTM D226, Type 1, 15# or type 2, 30# asphalt saturated organic felts, non-perforated]

The proper application techniques recommended by the manufacturer should be followed to ensure optimum performance of underlayment. The underlayment above eaves protection should be installed in minimum 1118mm (44”) widths, parallel to eaves lines with a minimum 100mm (4”) head lap and 150mm (6”) side lap. Fasten underlayment to roof deck with galvanized nails or staples sufficient to prevent wind lift and damage prior to installation. Extend underlayment a minimum 150mm (6”) up all walls, chimneys, skylights, etc. and seal corners with Solar Seal® #900 Sealant (or equivalent sealant). Underlayment must overlap valley protection 18” past centreline. Any underlayment damage must be repaired or replaced prior to Euroshield product application. For low slope underlay requirements see manual sections on Slope and Eave Protection.

VENTILATION

The proper ventilation of the attic area is an essential factor in attaining the maximum service life available from the building materials used in the roof assembly, in addition to improving heating and cooling costs. Overlooking this consideration may result in premature failure of the roofing system due to:

- 1) Accelerated aging of the EuroShield® System.
- 2) Rotting of the wood structure, wet insulation due to condensation.
- 3) Buckling of the roof deck.

Failure to adequately ventilate the attic space to meet minimum local building code standards may result in premature product failure and void your Euroshield® product warranty.

In the wake of technical advances and the proliferation of energy conservation measures, the ‘trapping’ of air and moisture in the attic is problematic. Improved insulation and better weather stripping are the two major reasons for this occurrence.

To correct this problem one needs to provide proper ventilation to ensure free and unobstructed air movement beneath the roof surface.

The National Building Code (Canada) requires that all roof and attic spaces above an insulated ceiling shall be ventilated with openings to the exterior to provide unobstructed vent areas of not less than 1 sq.ft./300 sq.ft with a suggested minimum of 1sq.ft/200 sq.ft. The vents shall be uniformly distributed on opposite sides of the building, in such a way that approximately 50% are near the lower part of the roof (inflow) and approximately 50% are near the ridge (outflow).

Cathedral ceilings covered with the EuroShield® System require adequate ventilation like any other roof to prevent damage to the products or structure. There should be a minimum space of 2 inches between the roof sheathing and the insulation to allow for unobstructed air movement.

When vapour barrier is used, cathedral ceilings require a minimum total net area for the inlet and outlet vents equivalent to 1/300 of the total ceiling area with a suggested minimum of 1/200. Cross ventilation should be ensured by locating half the required vent area at the eaves and the other half at the ridge.

Vent manufacturers should be consulted on the proper use of their products.

FASTENING

THE LOCKING VERMONT SLATE (mold #55/#57) USES SIX (6) NAILS. Nails should be placed where indicated by the “O” and by the arrows pointing to the target nail locations in the illustration below. Nails should be placed in the target nailing points at every location shown. Do not skip nailing locations.

Care should be taken to make sure nails are driven flush with the surface of the Shake panel. Nails driven below the panel surface such that a depression or cavity is created in the rubber panel, or nails driven on angle can reduce the effectiveness of the fastener and contribute to pooling of moisture in the fastener location. If using a compressor-operated nailer, adjust pressure to the point where the nail is driven flush with the panel surface.

No exposed standard roofing nails are permitted when installing Euroshield® products.

**ALWAYS PLACE NAILS WHERE INDICATED BY AN “X” or “O”
(Do not skip any nail locations)**



Vermont Slate Panel Loc with extended locking butt feature. (Note lock receiver channel below nailing points)

Each Eave/Rake/Valley **Starter Strip** is fastened using eight (8) 1 3/4" galvanized roofing nails. The metal drip edge flashing is applied to the wood deck at the eave edge, followed by the ice/water membrane which overlaps the drip flashing on the deck. The eave starter strip is applied over the ice/water barrier and drip flashing at the eave edge by 3/4" as indicated in the deck detail illustrations contained in this guide. Be sure to caulk the underside and topside edge of the valley starter as indicated in the illustrations in this guide. It is not a requirement to caulk under the starter strip at the eave edge and on the underside rake edge starter strip on gable ends.

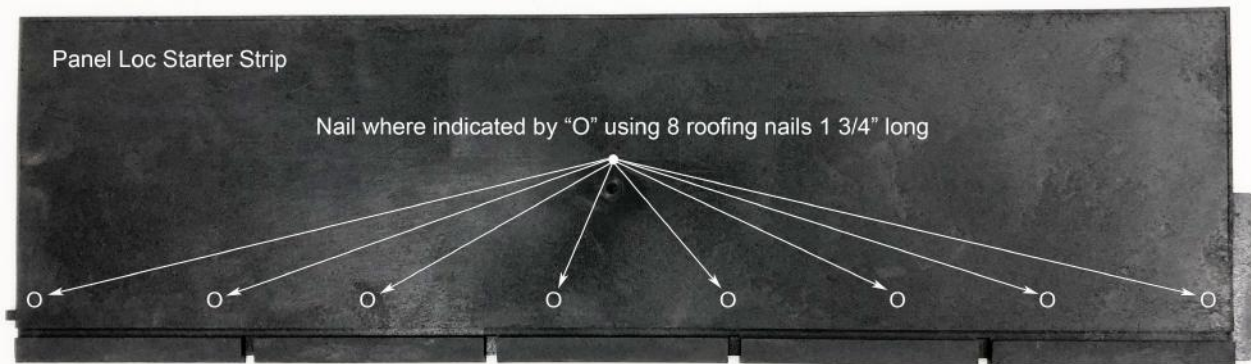

EAVE PANEL LOC STARTER STRIP

Gable end (rake) is prepared by applying the **gable/valley starter strip** over the woven synthetic underlayment vertically along the rake edge with the thicker portion to the outer edge of the rake and overlapping the rake edge by 3/4" (Option #1). A bead of Solar Seal #900 Sealant (or equivalent) is applied to the top of the starter strip as you move up the gable from eave to ridge and also to the top section of the panels, running vertically approximately 2" from the eave edge and into the locking channel, as they are applied up the rake edge prior to installing the next course. Do not apply this sealant until you are ready to place the last panel in the course at the rake edge on the gable.

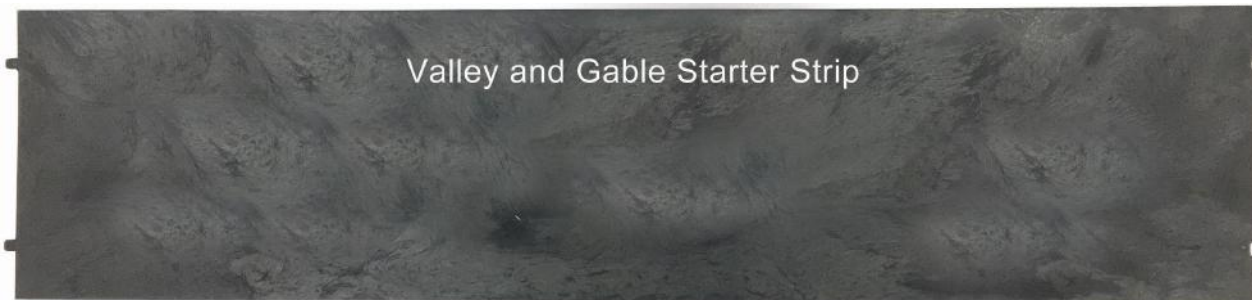

Valleys are prepared in similar fashion with the starter strip running vertically up the valley, placed over the metal valley, 2 inches out from the center on both sides of the valley. The thicker portion of the starter panel is closest to the center of the valley. Solar Seal #900 Sealant (or equivalent) is applied along the underside and topside inside edge in a continuous bead from eave edge to top edge of the valley prior to installation of the field panels.

NOTE: Eave starter strip is different from Gable and Valley starter strip. Please make sure you are using the locking channel starter strip at the eave edge only.

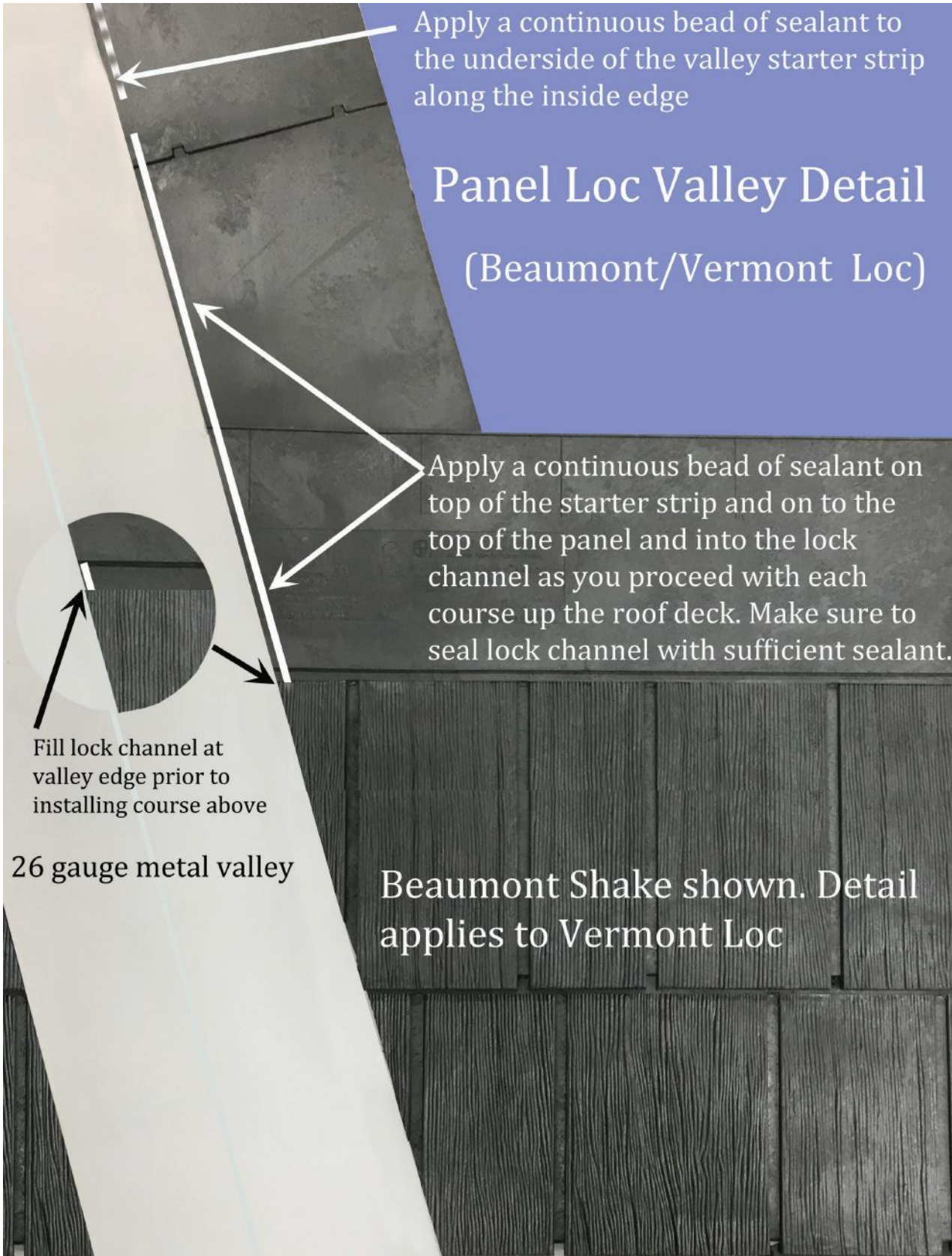

Apply a continuous bead of sealant to the underside of the valley starter strip along the inside edge

Panel Loc Valley Detail (Beaumont/Vermont Loc)

Apply a continuous bead of sealant on top of the starter strip and on to the top of the panel and into the lock channel as you proceed with each course up the roof deck. Make sure to seal lock channel with sufficient sealant.

Fill lock channel at valley edge prior to installing course above

26 gauge metal valley

Beaumont Shake shown. Detail applies to Vermont Loc

IMPACT AND HAIL RESISTANCE

EuroShield® demonstrates excellent resistance to mechanical impact and hail. The rugged and elastic nature of the rubber base material should weather the heaviest of storms.

SHADING

As a roof is viewed from different angles, and/or different lighting conditions, certain areas may appear darker or lighter. This inconsistency in colour has been designed to achieve the authentic look of shake.

INSTALLATION INSTRUCTIONS

ROOF DECK

See pre-installation and preparation section regarding material requirements and codes applicable. Check all roof gables for squareness. Check eave edge for squareness. Before work begins, the work of all other trades on the roof should be complete.

EAVE PROTECTION AND UNDERLAY

See pre-installation and preparation section regarding material requirements and codes applicable. Check and repair if necessary any damage to eave protection or underlayment, be sure the underlayment overhangs 25mm (1”), that head laps and side laps are sufficient to code and underlay extends up walls, chimneys, skylights, etc.

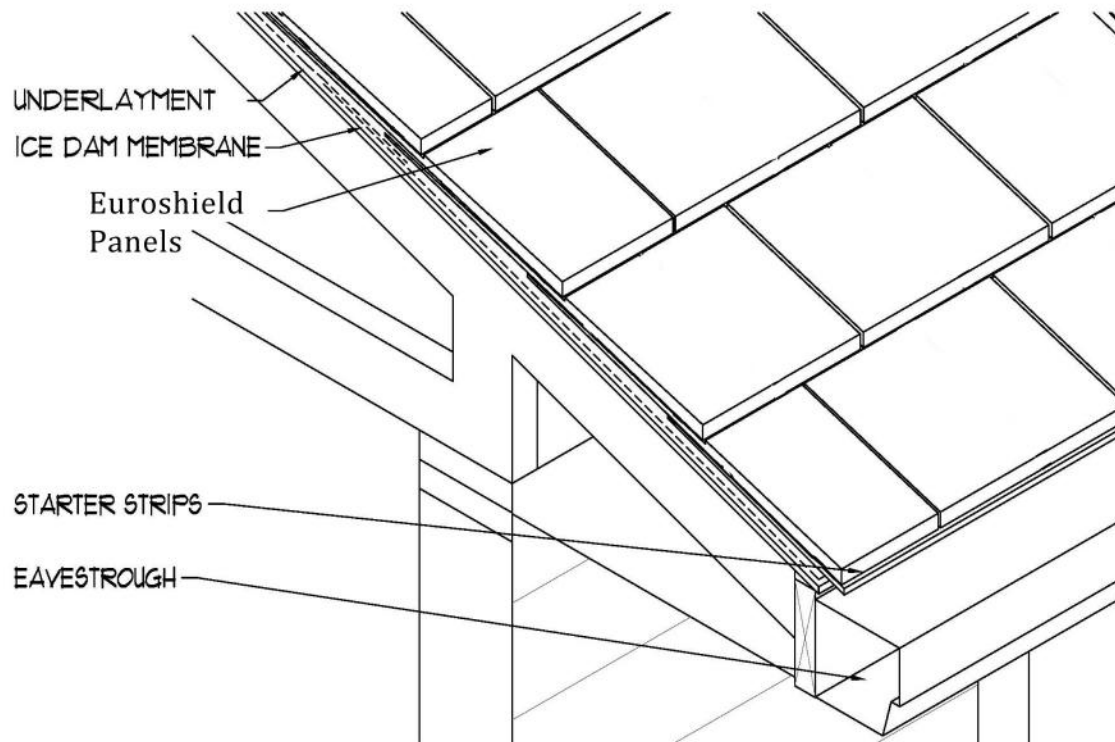

LOADING

Always load EuroShield® products toward the peak in such a manner as to not overload any one section of the roof, keeping in mind that the application will start at bottom of the roof.

Distribute materials to allow for close proximity during installation. Do not overlap bundles on the roof. Each bundle should lay flat on the roof.

VALLEYS, PROTRUSIONS AND OPENINGS

Take extra care to make sure underlayment and eave protection is sealed and watertight at all valleys, chimneys, protrusions and openings.

Apply one layer of peel and stick to the valley with 24 to 36 inch metal valley on top.

Apply Valley Starter Strip up both sides of the valley, 2 inches out from the center of the valley, after applying a continuous bead of caulk to the roof deck 3 inches out from the center of the valley from ridge to eave. Nail starter where indicated on the panel.

Start the Slate panel 2 inches from the centre of the valley and crop the top of each piece similar to asphalt shingles.

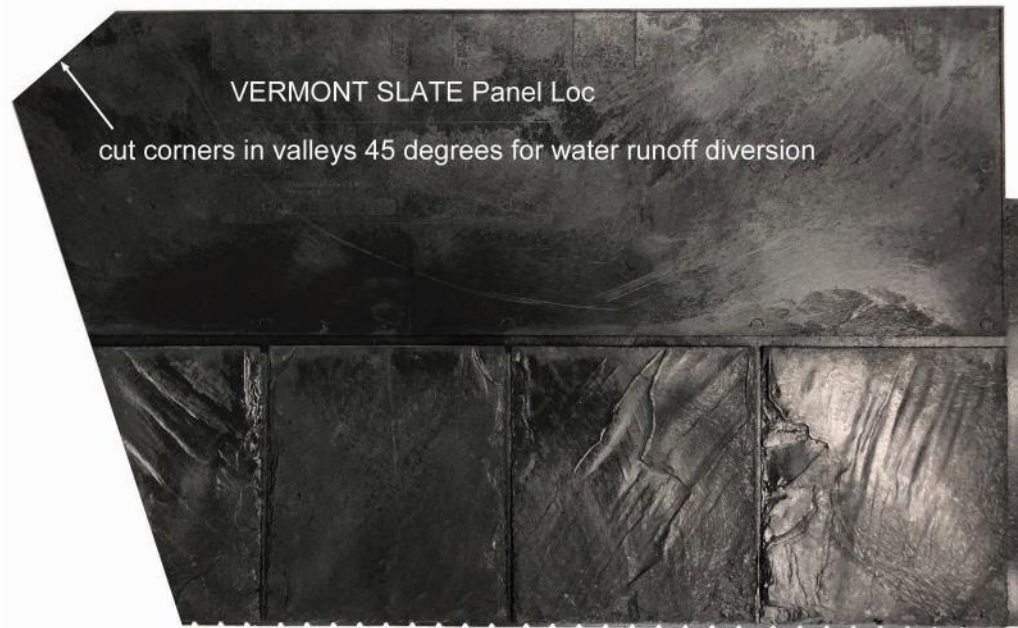

If a chimney is more than 750mm (30”) wide, building code demands a saddle be built for better drainage. A saddle need not be installed if a sheet metal flashing is used that extends up the chimney to a height equal to not less than one sixth the width of the chimney, but not less than 150mm (6”), and up the slope to a point equal in height to the flashing on the chimney, but not less than 1.5 times the slate exposure. Provincial building code demands flashing installation on all roof/wall intersections, thickness described previously.

Circular chimneys are flashed using a metal flashing (provided by mechanical contractor). Flange of flashing is to be woven into EuroShield® courses at top of the slope and sealed around complete flange with Solar Seal #900 sealant (or equivalent).

Plumbing vent stacks are flashed using a metal vent pipe flashing, metal or a flexible rubber flashing (normally supplied by mechanical contractor,) and woven into the EuroShield® courses at the top of the slope.

Note – if mechanical contractor is flashing, be sure they are on site before commencing EuroShield® application.

Ensure all other protrusions are properly flashed and woven into the Euroshield® courses and sealed in a lightweight manner. For unique circumstances contact G.E.M.’s technical department.

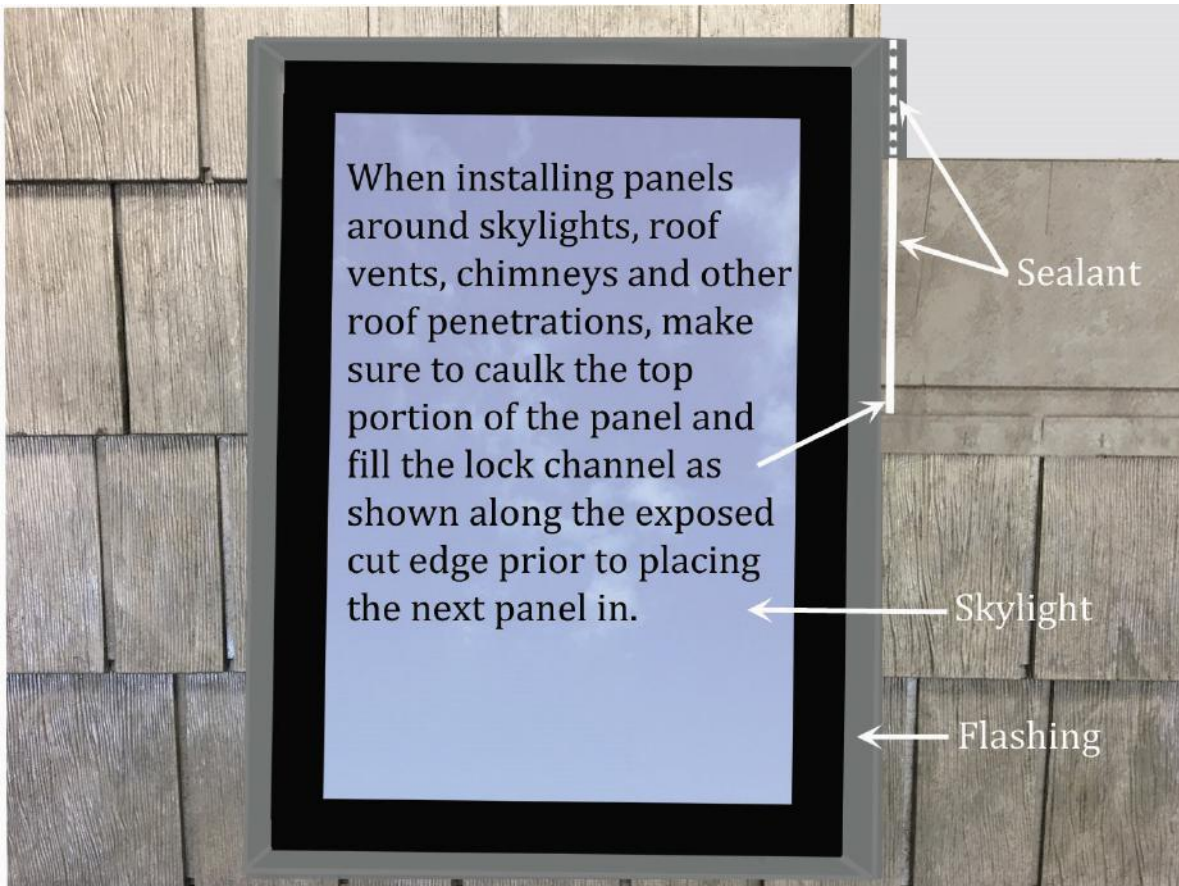

Note: Shake shown. Applies to Slate profile as well. Apply sealant at time of panel placement so it does not set prematurely.

VENT PIPE INSTALLATION

(Top and sides of pipe flashing covered by panels should be overlapped with 6" strip of ice and water membrane prior to installing roof panels)

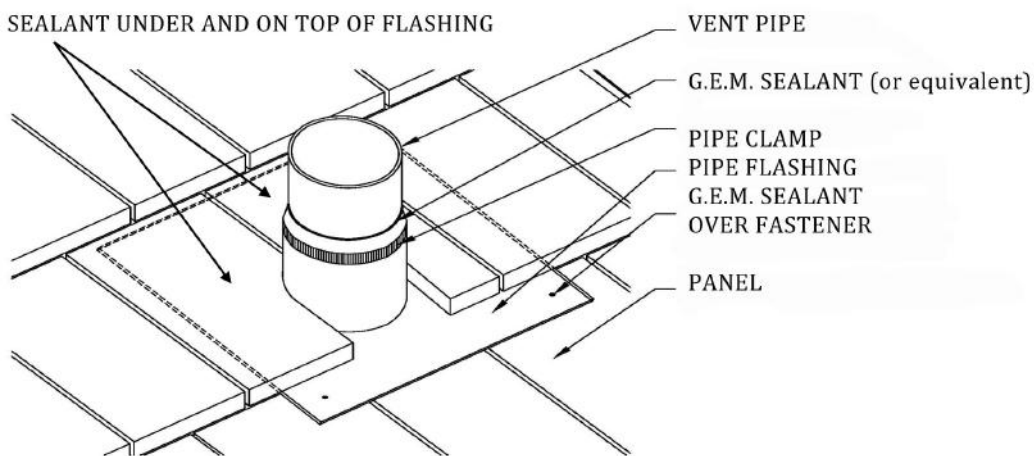

ATTIC VENT INSTALLATION

(Top and sides of attic vent flashing portion covered by panels should be overlapped with 6" strip of ice and water membrane prior to installing roof panels)

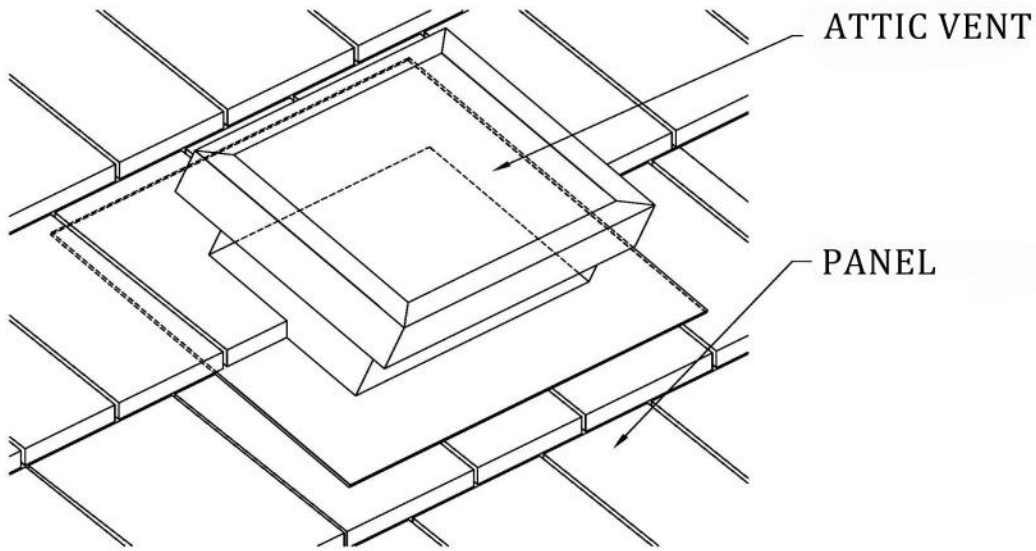

FLASHING DETAIL

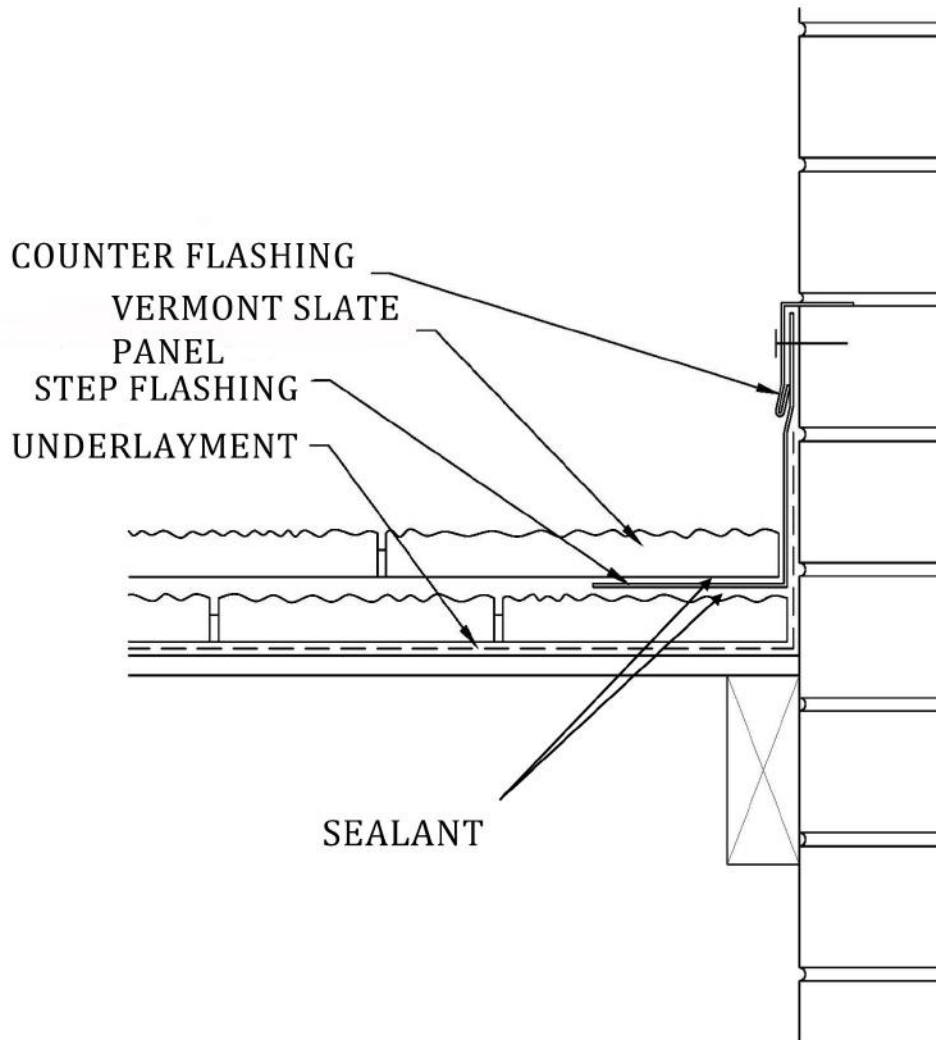

When dealing with step-flashing at vertical walls and chimneys as well as flashing around roof deck vents and skylights it will be necessary to trim off the extended butt edge lock so the flashing will not interfere with panels laying flat. Where this is required, cut off the portion of the lock required to allow the panel to lay flat and apply Solar Seal #900 or equivalent to the underside and fasten with a 2" brad nail along the butt edge where the lock has been trimmed off.

CHIMNEY INSTALLATION



G.E.M. Inc.
Global Environmental Manufacturing

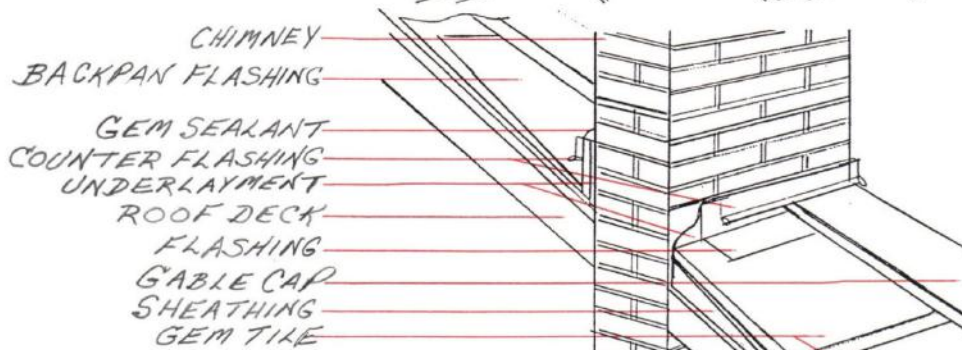
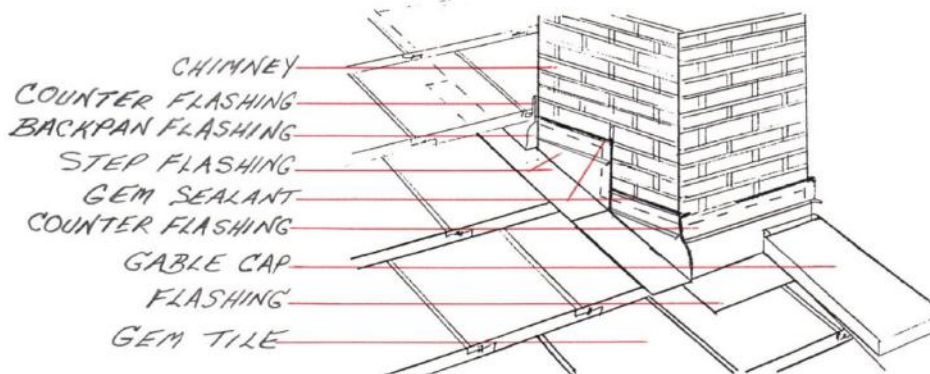
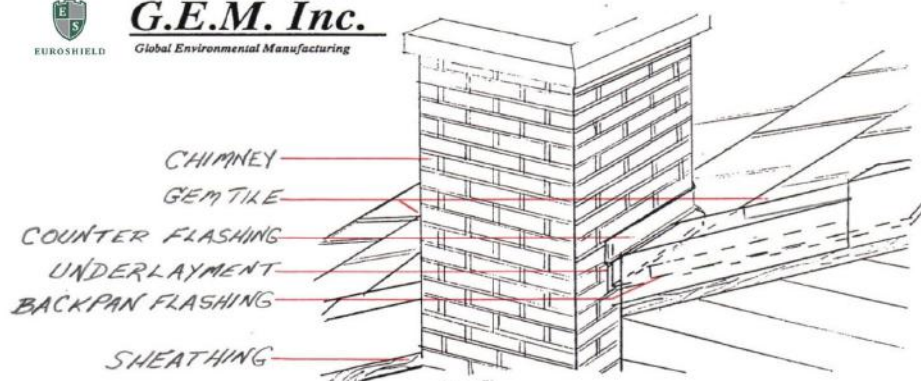

CHIMNEY
CH I

N.T.S.
KFC
08/2002

EAVE STARTER STRIP – (Note: Eave starter strip is different from Valley/Gable starter strip.)

After installing metal drip edge on eaves, install ice/water membrane such that the top edge is 18 inches inboard of the inside warm edge wall. Install **Panel Loc Eave Starter Strip Panels** maintaining a $\frac{3}{4}$ " overhang along eave edge. This first piece must be a part-panel (cut eave starter panel in half) so that the starter "keyway" (space between panels/tiles) does not line up with the "keyway" of the first full course of Vermont Slate Loc going down directly on top of the starter row. Fasten eave starter strip using 8 – $1\frac{3}{4}$ " roofing nails as shown in the diagram on page 11. Nails should penetrate the Fascia Board.

After the roof deck has been prepared and ice/water membrane and woven synthetic underlayment is in place (see illustrations to follow), begin the installation of the starter strips for eave, valleys and rake edges.

Starting at the left side of the roof eave edge, chalk a straight line 295mm (11–5/8") from the lower most point of the eave edge. Align the top edge of the eave starter strip with the chalk line such that the bottom edge of the starter extends $\frac{3}{4}$ " past the bottom of the eave edge.

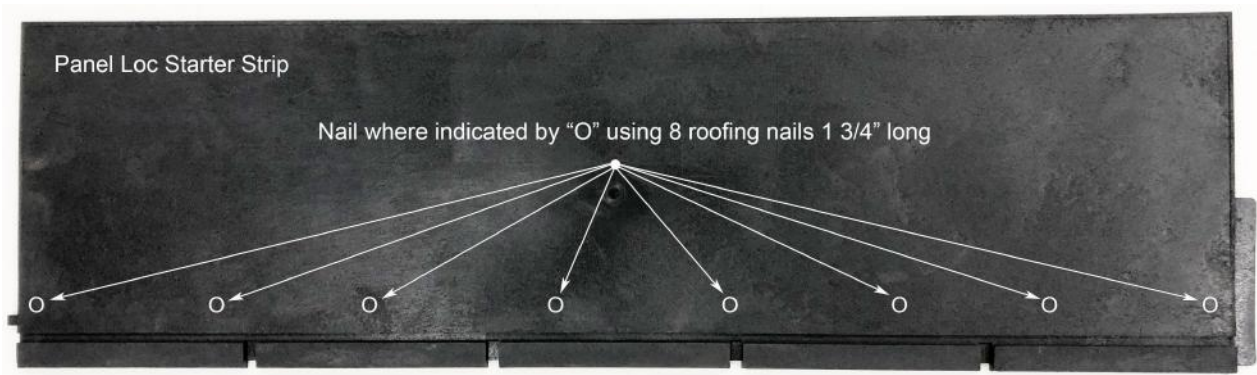

The first full panel course will lock into the eave starter strip located at the eave edge. The full panel must be a minimum of 5 inches from the edge of the starter strip panel.

VALLEY AND GABLE STARTER STRIP

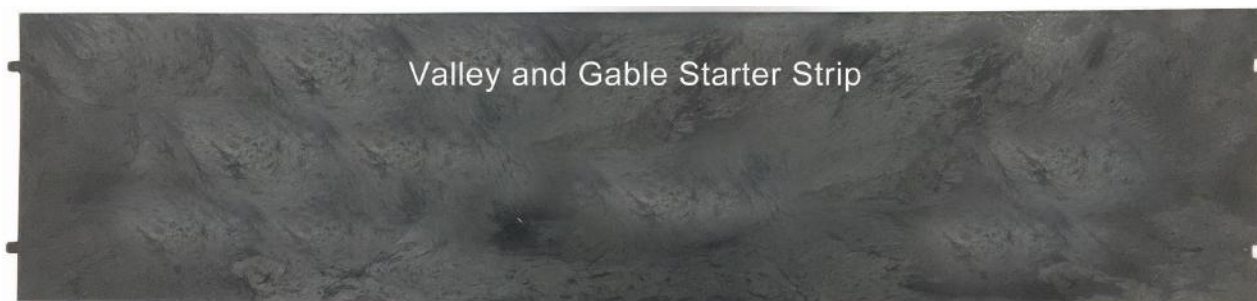

GABLE OPTIONS

There are 3 methods to finish the gable edge. Option #1 features the gable starter strip overhanging the rake edge on the gable end by $\frac{3}{4}$ " with the field panels trimmed to match the $\frac{3}{4}$ " overhang. Option #2 is a raised metal flashing detail (see illustration in Flashing Detail at back of guide) designed to hide the cut edge and provide uplift/blow-off protection in high wind regions. Option #3 is the same as with option #2 but with the addition of a decorative cap treatment. Both are shown in illustrations to follow.

Option #2 and #3 require the gable metal flashing detail to be applied to the deck after installation of the ice/water membrane and synthetic underlayment. Apply the starter strip (with a continuous bead of adhesive/sealant to the underside of the starter strip along the edge of the starter strip closest to the gable flashing detail) on top of the gable flashing such that there is a minimum $\frac{3}{16}$ " space left between the starter strip/panels and the vertical portion of the metal flashing as shown in the illustration. The eave starter strip will then line up against the rake starter edge at the eave edge as shown in the illustration below.

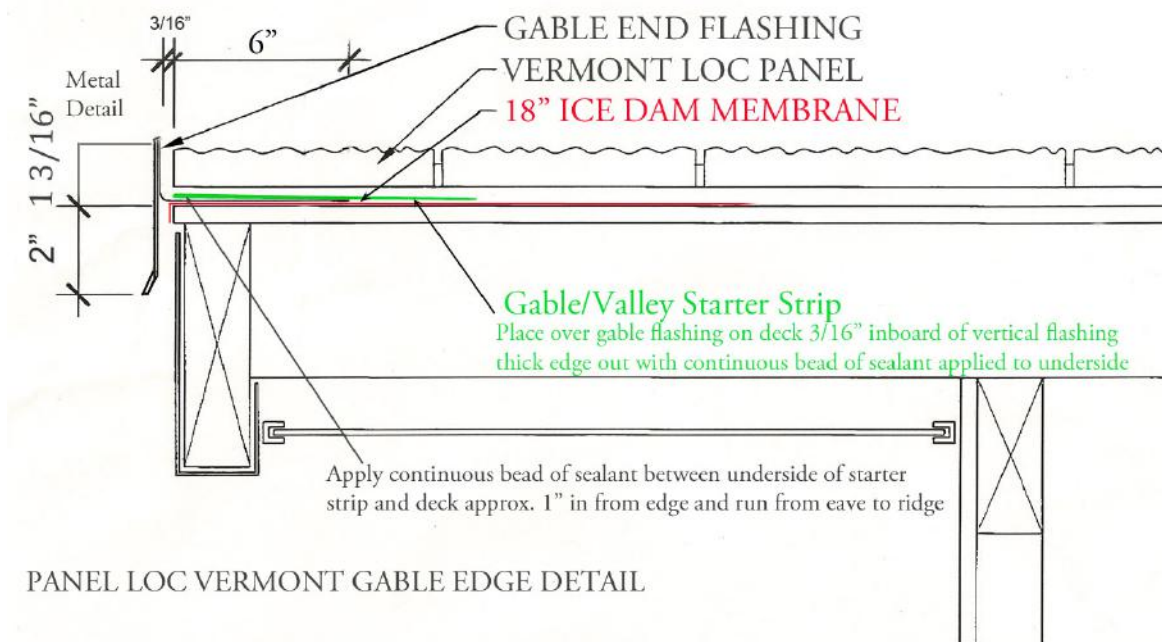

Option #2 and #3 gable detail (above). Continue with gable starter up the roof to the peak, fitting the panels together as shown in the illustration below (Gable/Rake and Eave Detail).

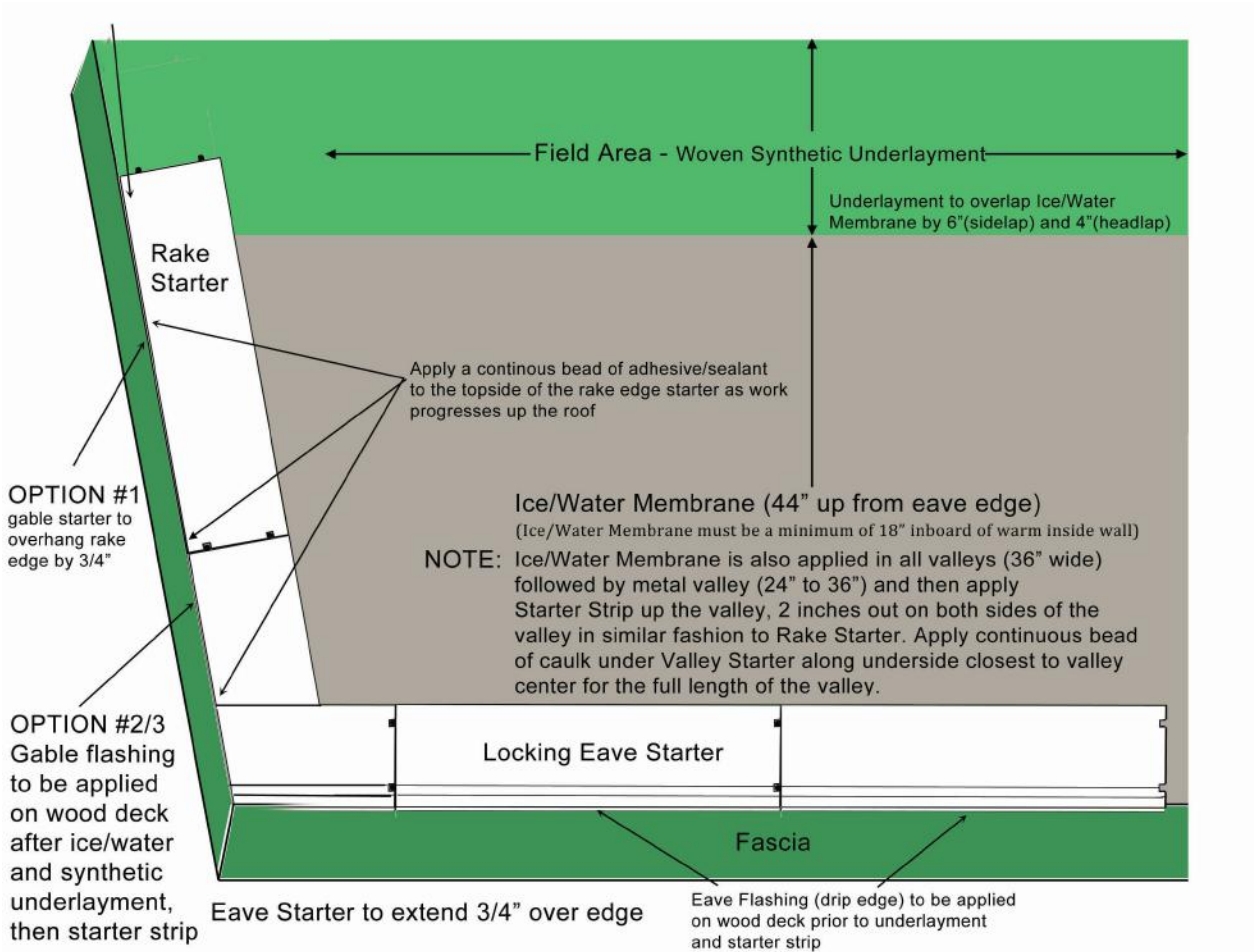

Vermont/Granville/Beaumont/Harvest Rake and Eave Edge Detail

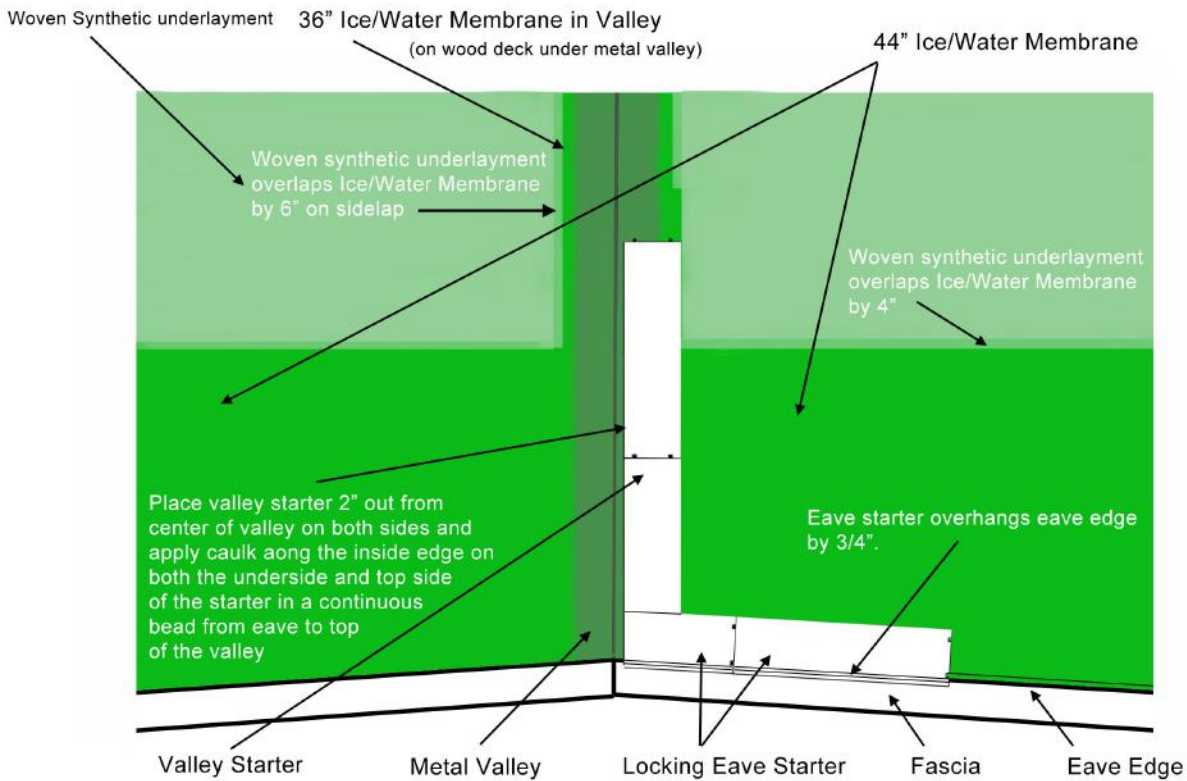

In the case of the Locking Butt Vermont Slate, place the panel such that the lock strip will drop into the channel in the panel on the course below, **line up the outer edge of the “weather strip tab” found on the right edge of the panel to correspond to the correct row offset** and then push the panel down firmly and evenly so the lock engages fully into the slot in the channel. **Make sure the channel is free of dirt and debris prior to engaging the lock.** See diagram below.

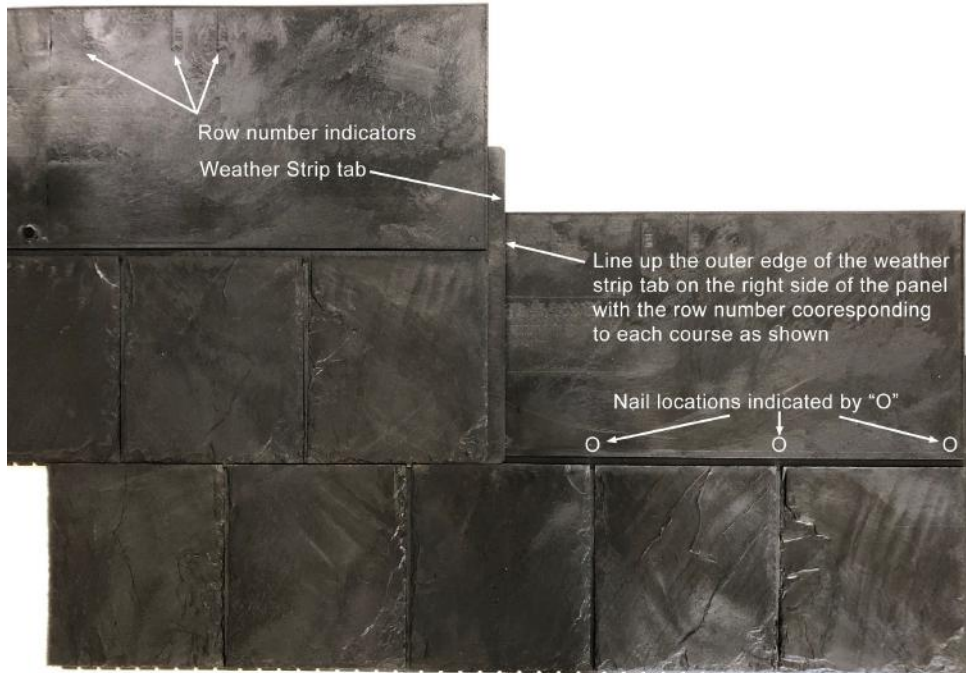

Verify the course is tightly and fully locked its entire length and then place the 1 3/4" roofing nails in the target locations (6 nails per panel) to fasten the panel in place.

Euroshield® Installation Guide –VERMONT SLATE Panel Loc January 2020

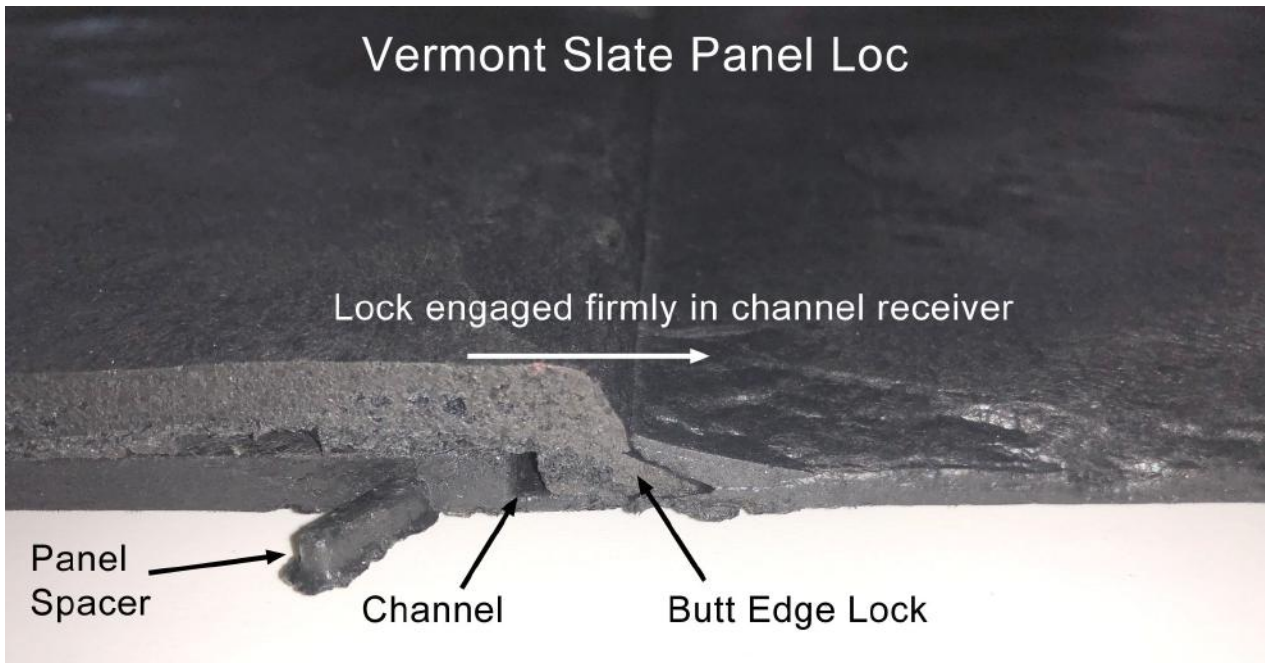
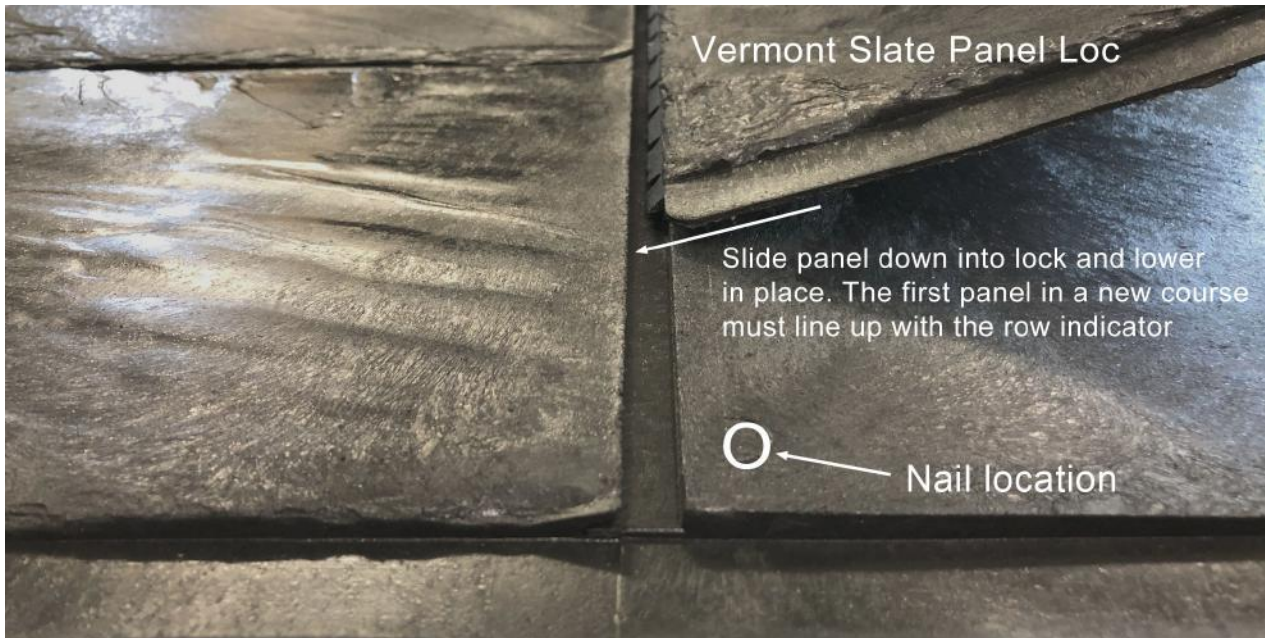

Continue in this manner until the right gable is reached (if working left to right) and trim the last panel as per option #1 or #2 requirements. When installing using option #2, gable flashing with the raised 1 3/16" high cover section is required on the deck's gable edge regardless of the use of caps in option #3.

OPTION #1 - Apply ice/water membrane and synthetic underlayment to deck. Position gable starter along rake edge starting at the eave edge, overhanging the rake edge by 3/4" and nail in place using 6 nails per panel as shown in the illustration. Continue up the gable to the ridge. Trim Euroshield® Installation Guide –VERMONT SLATE Panel Loc January 2020

the field panels such that they line up with the starter strip $\frac{3}{4}$ " overhang. Follow the details in the illustration below for placement of sealant.

Option #1 Starter strip and field panels overhang rake edge on gable end by $\frac{3}{4}$ "

HIGH WIND REGIONS USE OPTION #2/3

Option #2 Gable end flashing detail attached to wood deck after ice/water and synthetic underlayment. Apply starter strip maintaining $\frac{1}{4}$ " gap between raised flashing and starter/field panels. See guide for details.

Option # 3 Use Option #2 and finish with decorative caps as per details in guide.

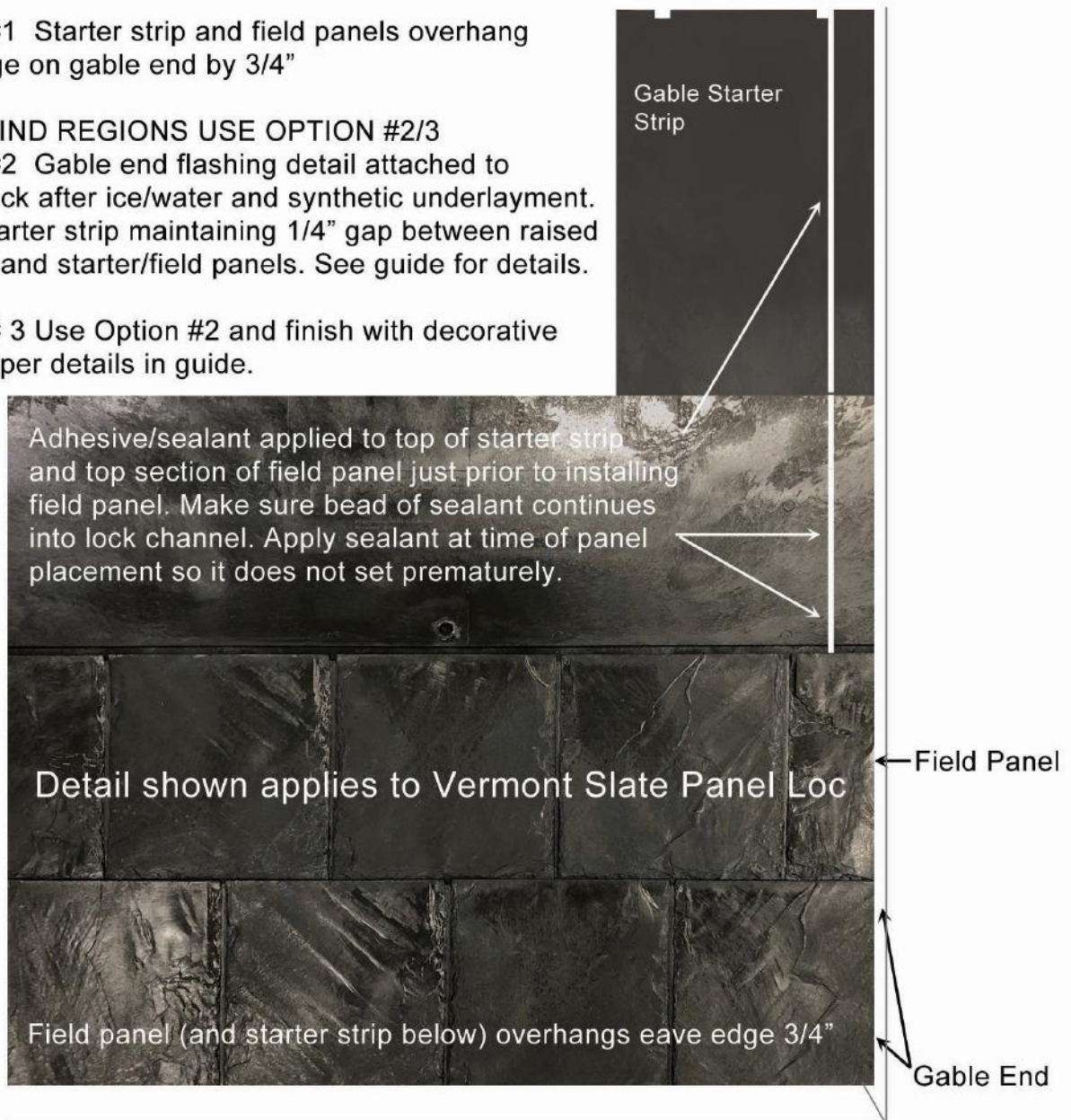

OPTION #2 - use a gable flashing with a $1 \frac{3}{16}$ " raised edge to hide the cut edge at the gable edge. Using this method, leave approximately $\frac{3}{16}$ " of space between the panel and the raised metal flashing to allow for expansion/contraction and run-off. **This flashing detail will hide the cut edge and provide maximum gable edge protection in high wind regions, helping prevent blow-offs.**

Note: Granville Slate is shown in the illustration below however detail applies to Vermont Slate, Beaumont Shake and Harvest Shake install.

GRANVILLE SLATE (Shown)

**Gable Edge Metal Flashing
Option # 2**

**3/16" space between
panel and raised
metal edge**

**Metal Flashing Detail
1 3/16" high raised edge (to
hide cut edge) up gable
from eave to ridge**

OPTION #3 - use the same flashing (see Gable Flashing Detail at back of Guide) on the gable from eave to ridge. Install panels in the same manner (over the metal flashing, underlayment and starter strip) and then install Beaumont Shake Caps along the gable edge for a decorative finished slate cap look (see below). For additional blow-off protection in windy areas we recommend the use of Solar Seal #900 adhesive and 2" galvanized or stainless 18-gauge brad nails at the butt edge corner of each cap along the rake edge, penetrating the surface of the deck and the fascia. **Do not** use standard roofing nails with exposed heads.

Note: Granville Slate gable caps shown in illustration below however detail applies to Vermont Slate, Beaumont Shake and Harvest Shake install.

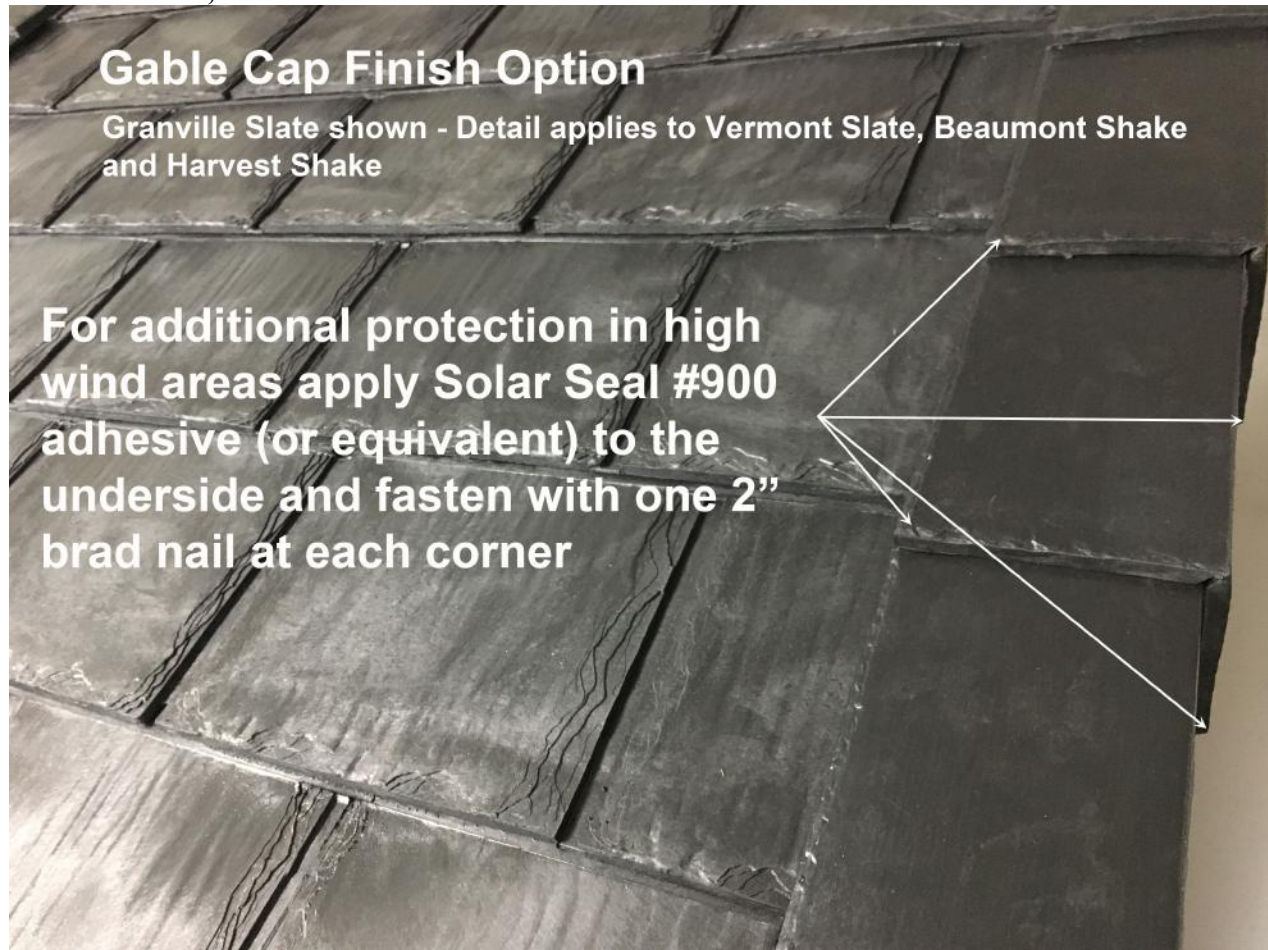

Apply Solar Seal #900 (or equivalent) adhesive at butt edge underside corners and fasten with a 2" galvanized or stainless 18 gauge Brad Nail at each corner. **Do not use standard roofing nails with exposed heads.**

Follow the course offset in the back of this guide, filling in each course. Continue in this manner until the right/left gable is reached and trim the last panel such that you have $\frac{3}{4}$ " overhang on the gable end (Option #1) and are flush with the edge of the eave starter overhang. Continue up the roof course-by-course following the layout pattern for the mold number you received in your shipment (shown on front of panel).

Do not nail the face of the panel as the fascia will have to be installed under the drip edge.

If working left to right *out of a valley*, place the top left portion of the panel in the valley such that the diagonal cut down, 2 inches out from the centerline of the valley, from left to right cuts through the entire panel. The overlap on each piece is fitted into the overlap of the preceding one. At the ends of the courses trim panels (using a power saw or knife), to be flush with the edge. Care should be taken to keep the cuts straight.

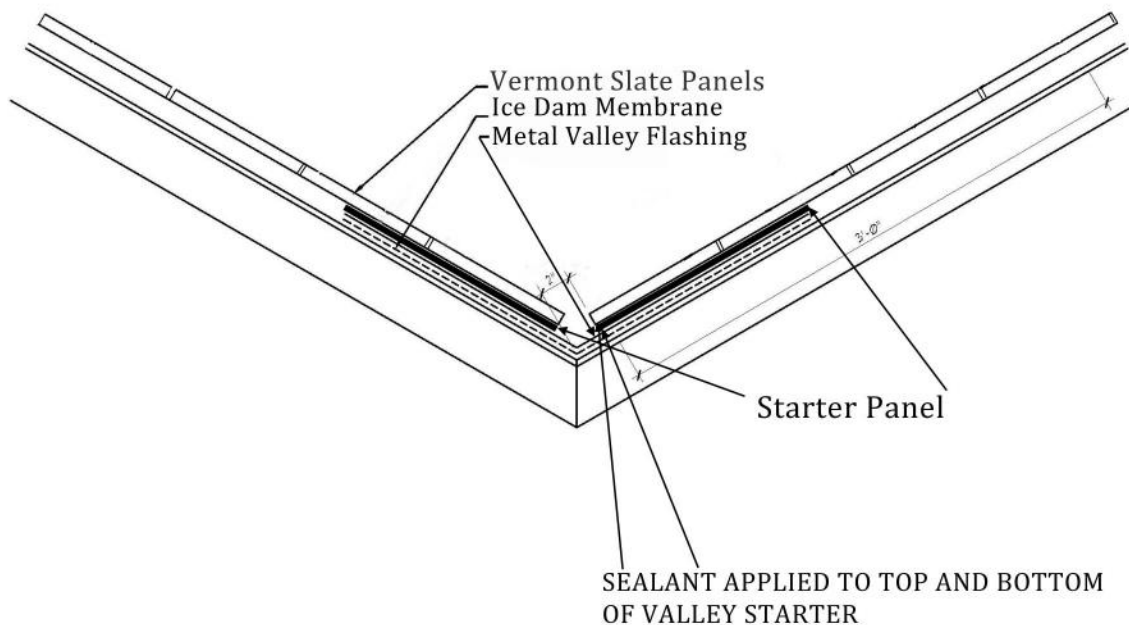

Panels are installed using six (6) 1 3/4" galvanized roofing nails for the Vermont Slate Panel Loc. Always nail in all the target locations indicated on the panel by "O". Do not skip any nailing locations.

ROOF JACKS

Roof Jacks may be fitted and removed in the same manner as with asphalt shingles however a section of the lock (sufficient to allow the jack to be shifted sideways and removed) must be trimmed off the panel in the course above. Depending on where and how much of the lock has been removed, it may be necessary to apply a dab of Solar Seal #900 to the underside of the panel where the lock was removed and fasten with 2" brad nails.

Upon reaching the peak of the roof, the last row of panels will have to be trimmed along the upper edge, flush with the ridge, unless a ridge vent is to be used, in which case the panels will need to be trimmed to allow for the opening of the ridge.

Walls, chimneys, plumbing vents, attic vents, skylights etc. must be flashed and sealed as described in other sections of this manual, and woven into the Euroshield® as the field panels are progressively installed up the slope of the roof.

RIDGE CAP

Caps can be installed over ridge venting. Please consult the ridge vent manufacturer for details on application. Note that the caps cover approximately 4.5” on each side.

When the field panels are completely installed the ridge cap panels can be added. Ridge caps are installed starting from east or south side so they do not face prevailing winds.

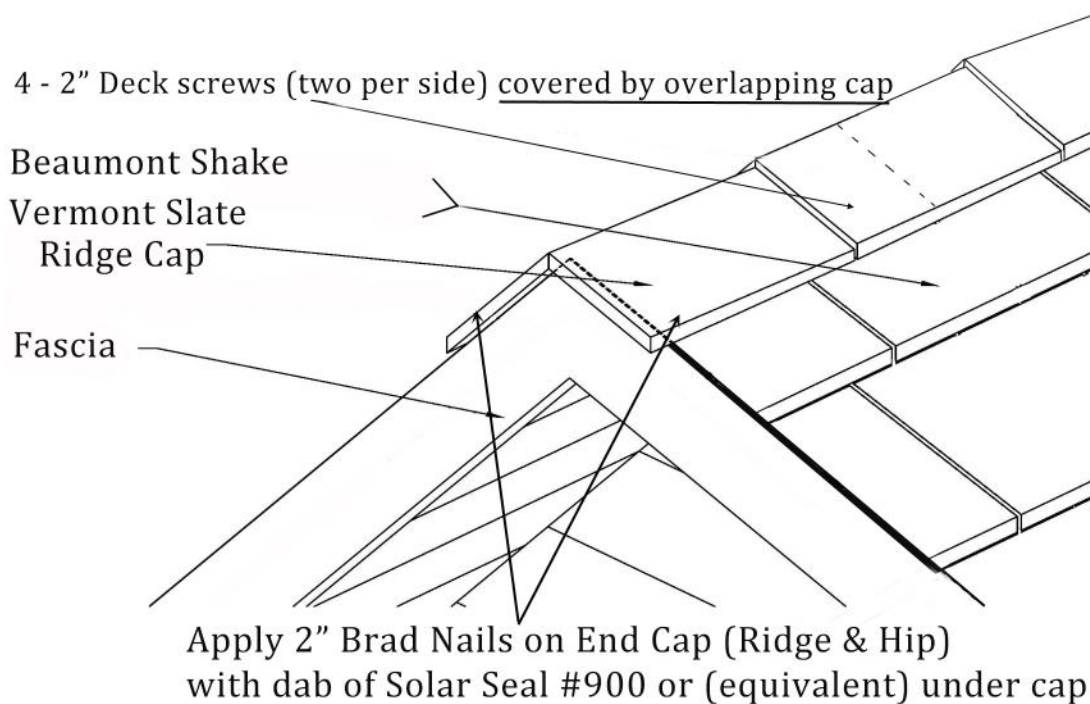

Each cap is fastened using four (4) 2” galvanized deck screws, two (2) on either side. The last cap must be “face fastened” using a dab of Solar Seal#900 (or equivalent) under the cap at the fastening point and a 2 inch “brad” nail fastened through the cap and sealant.



Note: Shake cap shown. Location for deck screws is the same for slate cap.

HIP CAP

The hip caps are the same piece as the ridge caps and are installed in the same manner as ridge caps. Beginning at the eave, overhang the first cap by $\frac{3}{4}$ " and fasten where indicated in the diagram on page 24. The first cap is additionally fastened with two 2" brad nails, one on either side of the cap, near the butt edge as shown in the illustration. Place a dab of Solar Seal #900 (or equivalent) under the cap at the fastening point prior to placing the brad nail. Place the next cap

above the first and lower until the nibs on the underside of the cap touch the top portion of the cap below. The correct exposure of 9" for the Vermont Slate cap is now set automatically. Continue working your way up the hip in similar fashion, fastening each cap with four (4) 2" galvanized deck screws, two (2) on each side such that the overlapping cap covers the fastener. Note that the caps are notched at the butt edge to allow for variable pitch applications and the notch can be cut (widened) further to allow for steep pitch applications.



Caps have a molded "V" on the underside as can be seen in the illustration above. Cutting along the butt-side edge of this "V" will allow for a clean edge (no exposed cavities) when installing the first hip cap at the eave edge where 2 roof planes meet at 90 degrees.

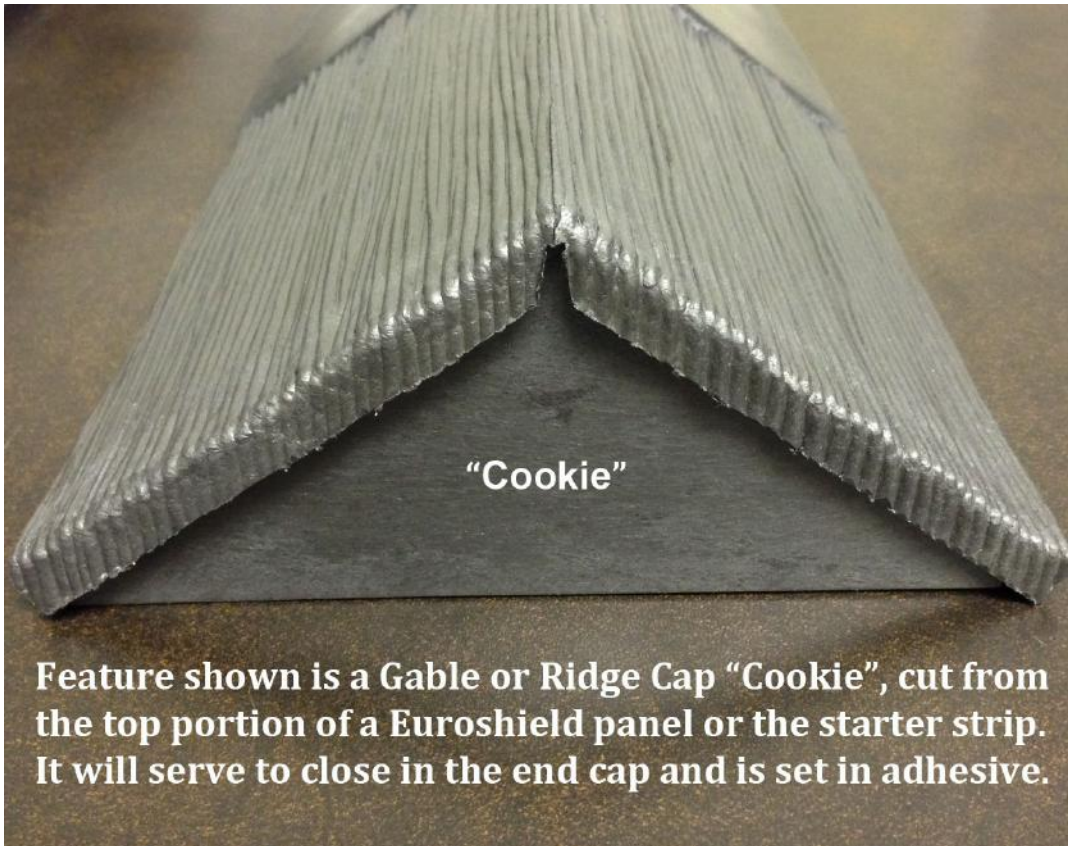

Feature shown is a Gable or Ridge Cap “Cookie”, cut from the top portion of a Euroshield panel or the starter strip. It will serve to close in the end cap and is set in adhesive.

A “cap cookie” can be used at the bottom of a hip and on ridge ends to finish. (Beaumont Shake cap shown)

HIP DETAIL AT RIDGE

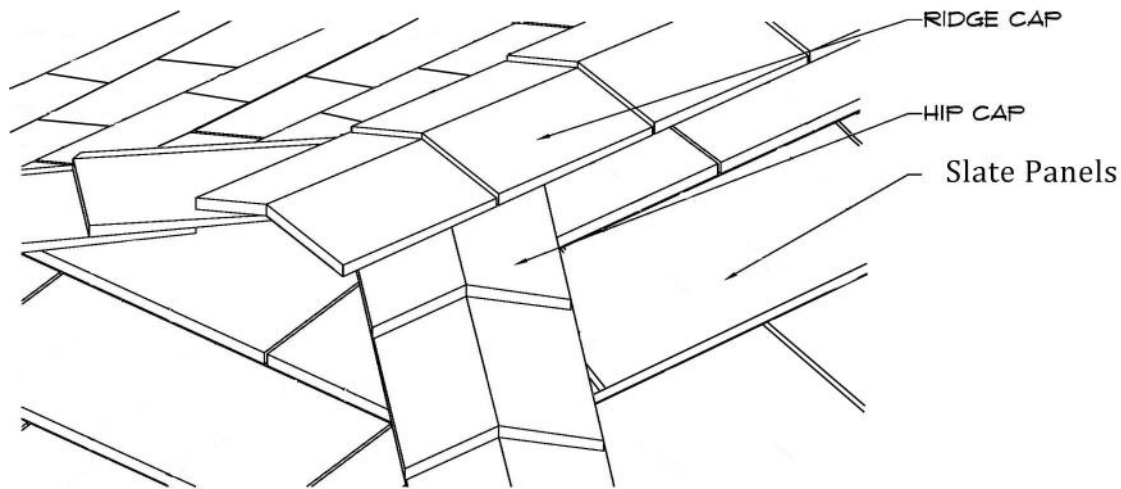

VALLEYS

Width - 24” to 36” for Open Types of Metal:

Copper

Stainless Steel

Color Clad Steel

Color Clad Aluminum

“W” or “V” Valley

Note: When fastening shingles in valley areas, nail as far away from the centre of the valley as possible to avoid penetrating the valley metal.

DETAIL FINISHING

The above instructions should conclude the application of the EuroShield® System, excepting the completion of the details on walls, chimneys, skylight, vents etc. Pay special attention to and follow the layout pattern found at the back of this guide, specific to the mold number.

They should be sealed with Solar Seal #900 sealant (or equivalent) and be flashed appropriately in accordance with C.R.C.A. Standard specifications, in conjunction with G.E.M. detail drawings contained within this Guide.

Plumbing vents must be sealed to the pipes and clamped according to pipe flashing manufacturer’s instructions.

MAINTENANCE

The EuroShield® System requires very little ongoing maintenance. Renew Solar Seal #900 sealant (or equivalent) on details and exposed fastener heads from time to time as required, maintain gutters, troughs, downpipes and drain to remain free of debris so drainage water flows away unrestricted. Should alterations be required involving the roof as time goes on, please contact G.E.M.’s technical department for assistance. Repairs performed with non – EuroShield® system components or incompatible materials will void the EuroShield® warranty.

Vermont Slate/Beaumont Shake Metal Profiles - Recommended 26 Gauge

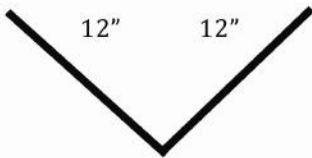

24" VALLEY
("W" or "V" Valley)

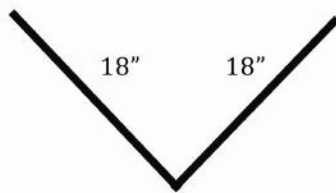

36" VALLEY

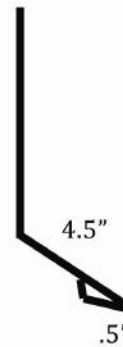

WALL FLASHING

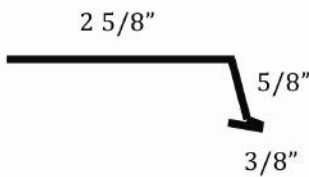

EAVE DRIP EDGE

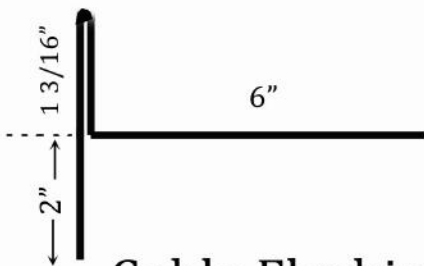

Gable Flashing

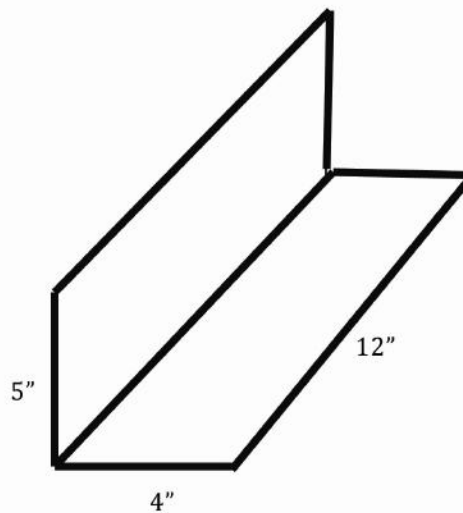

STEP FLASHING

Panel Layout Pattern

The layout pattern below for the Vermont Slate LOC helps minimize the effect of discernable patterns and ensures the individual keyways on each course do not line up with the keyways in the course below, taking care not to expose nails in the open keyways below. In no case shall a panel joint (area where two panels meet in a course) be within 5 inches of the panel joint in the course below or above. **The layout pattern is indicated by row markings (row number line indicators) at the top of each panel. Use the row number offsets as your guide for panel placement, lining up the weather strip tab on the right side of the panel with the row line indicator.**

VERMONT SLATE LOC (Mold # 55/#57) LAYOUT PATTERN

The illustration on page 36 is an example of the recommended panel offset/layout. Please make sure you match the layout pattern to the mold number on the product you have received. It is marked on the front side of the panel. It is intended to show how each course should be started to minimize the effects of patterning on the roof. Be sure to fasten the nails where indicated by “O” such that they are not visible in the keyway as the next course of panels is applied. It is recommended to keep panel-to-panel joints (where 2 panels meet in a course) five (5) inches or more from a similar panel-to-panel joint in the course below.

DO NOT install straight up the roof, as is often done with asphalt shingles, offsetting the same distance each course as you will create a step-like or “ladder” effect which will be visible on the roof.



If you have any questions regarding the layout, or any other installation-related questions, please call our North American Toll Free Number (877) 387-7667 prior to beginning installation.

Please Note:

Vermont Slate Loc (Mold #55/#57) requires **6 nails per panel** as indicated on the panel by an “O”.

Always place nail where indicated by an “O” – do not skip any nailing locations.

Follow the row numbers as indicated on the top section of each panel for the offsets shown below.

VERMONT SLATE Panel Loc MOLD #55/#57 Layout Pattern Row 1~6 and repeat

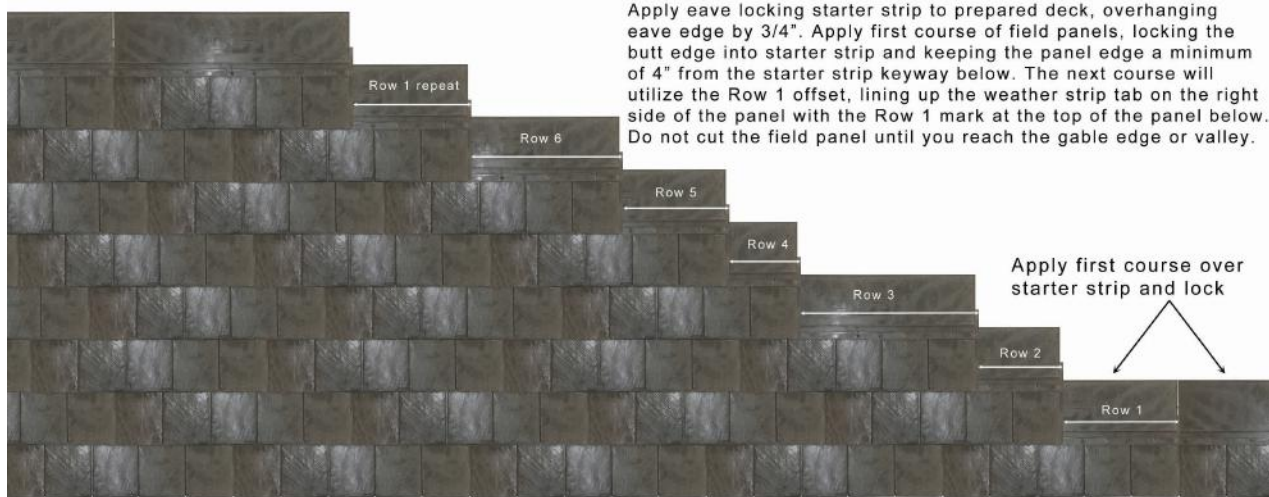

Measurements are taken from the outside edge of weather strip tab on the right side of the panel.

Thank you for your purchase of Euroshield® roofing products.